

# PRODUCT DRAWING

| REV. | DATE | DESCRIPTION |
|------|------|-------------|
|      |      |             |
|      |      |             |
|      |      |             |

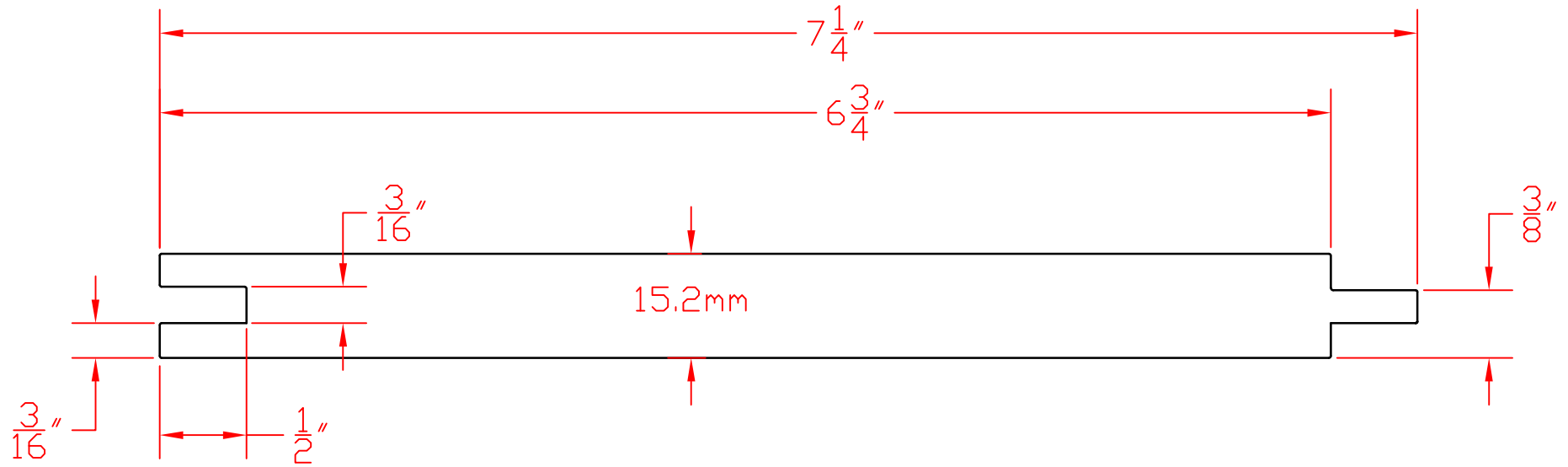

## 8" SHIPLAP

NOTE:  
SURFACES AVAILABLE: SMOOTH, WOOD GRAIN or  
ROUGH SAWN (BRUSHED)

THIS DOCUMENT CONTAINS  
PROPRIETARY INFORMATION WHICH  
SHALL NOT BE REPRODUCED,  
TRANSFERRED TO OTHER DOCUMENTS,  
DISCLOSED TO OTHERS, USED FOR  
MANUFACTURING OR ANY OTHER  
PURPOSE WITHOUT PRIOR WRITTEN  
PERMISSION BY JAIN AMERICA HOLDINGS

**JAIN BUILDING PRODUCTS**

8" SHIPLAP

NUCEDAR PRODUCT DRAWING

| APPROVALS |     |         | DATE        |                     |              |      |
|-----------|-----|---------|-------------|---------------------|--------------|------|
| DRAWN     | PHS | 3/12/19 | SIZE        | MACHINE ID.         | DRAWING NO.  | REV. |
| ISSUED    | PHS | 5/1/19  | A           | WEINIG              | SL-005r02    | 2    |
| REVISED   | PHS | 1/13/20 | SCALE: FULL | FILE: SL-005r02.dwg | SHEET 1 OF 1 |      |